

Technical Bulletin # 615E

### Bulletin Description

This bulletin promotes the use of CHOCKFAST® Red or ESCOWELD 7505E/7530 as a grout for setting large anchor bolts in large, deep anchor bolt pockets. Typical 2-part epoxy chocking compounds CHOCKFAST Gray, while good for use in smaller holes, should not be used in such cases because the exothermic heat created by their large mass may crack the epoxy.

Deep anchor bolt pockets - up to 2 meters (6 ft) long and 200mm (8") wide - may be filled conveniently with a single placement of CHOCKFAST® Red or ESCOWELD 7505E/7530.

The gentle exotherm of CHOCK-FAST® Red and ESCOWELD 7505E/7530 allows grout placement around large bolts to be executed with a single pour in extremely hot and humid climates with negligible shrinkage.

### Design Considerations

Most process machinery is critically aligned within hundredths of a millimeter tolerance. Therefore, final horizontal leveling pours in contact with critically aligned baseplates, rails, soleplates or coupled machinery should be limited to a depth of 100mm (4").

Two separate grout pours are required:

- ① The first pour in the Anchor Bolt Pocket filled is made using CHOCKFAST® Red or ESCOWELD 7505E/7530
- ② The Final Leveling Pour under the critically aligned machinery is then made using CHOCKFAST® RED or ESCOWELD 7505E/7530

**Date** June 2018

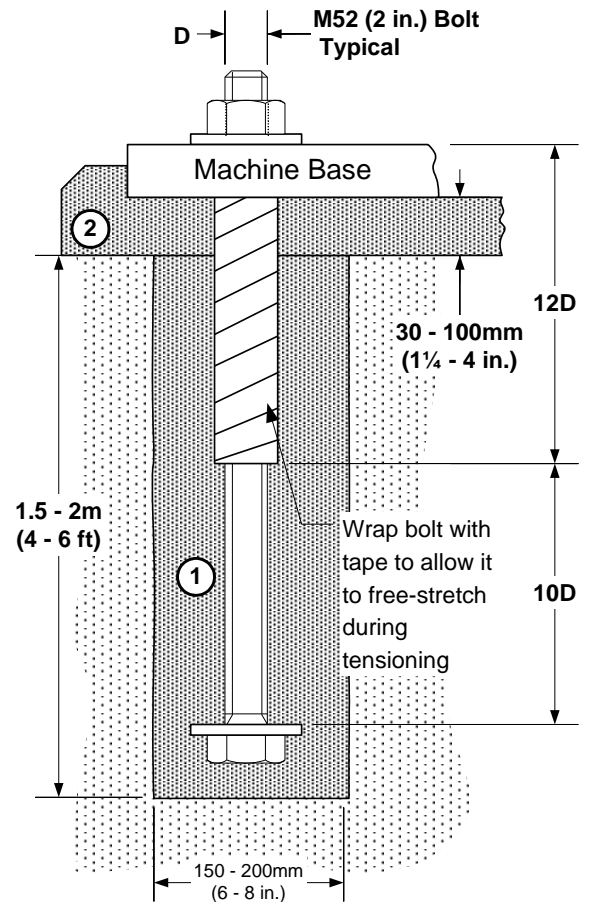

**General:** Every reasonable effort is made to insure the technical information and recommendations on these data pages are true and accurate to the best of our knowledge at the date of issuance. However, this information is subject to change without notice. Prior versions of this publication are invalid with the release of this version. Products and information are intended for use by qualified applicators that have the required background, technical knowledge, and equipment to perform said tasks in a satisfactory manner. Consult your local distributor for product availability, additional product information, and technical support. **Warranty:** ITW Performance Polymers, a division of Illinois Tool Works Inc., warrants that its products meet their printed specifications. This is the sole warranty. This warranty expires one year after product shipment. **Warranty Claims:** If any product fails to meet the above, ITW Performance Polymers will, at its option, either replace the product or refund the purchase price. ITW Performance Polymers will have no other liability for breach of warranty, negligence, or otherwise. All warranty claims must be made in writing within one year of the date of shipment. No other claims will be considered. **Disclaimer:** ITW Performance Polymers makes no other warranty, expressed or implied, and specifically

disclaims any warranty of merchantability or fitness for a particular purpose. Suggestions concerning the use of products are not warranties. The purchaser assumes the responsibility for determining suitability of products and appropriate use. ITW Performance Polymers' sole liability, for breach of warranty, negligence or otherwise, shall be the replacement of product or refund of the purchase price, at ITW Performance Polymers' election. Under no circumstances shall ITW Performance Polymers be liable for any indirect, incidental or consequential damages. **Modification of Warranty:** No distributor or sales representative has the authority to change the above provisions. No change in the above provisions will be valid unless in writing and signed by an officer or the Technical Director of ITW Performance Polymers. No term of any purchase order shall serve to modify any provision of this document. **Mediation and Arbitration:** If any dispute arises relating to products or product warranties, either the purchaser or ITW Performance Polymers may a) initiate mediation under the then current Center for Public Resources (CPR) Model Procedure for Mediation of Business Disputes, or b) initiate a non-binding arbitration under the rules of the American Arbitration Association for the resolution of commercial disputes.