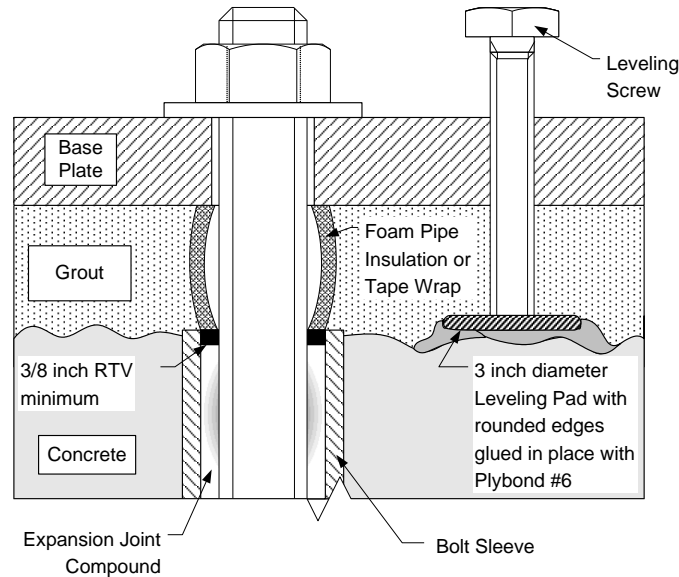

Technical Bulletin # 1647D

Bulletin Description

This bulletin illustrates the recommended method of protecting an anchor bolt and installing a leveling screw prior to the pouring of Chockfast or Escoweld epoxy grout. The normal sequence of preparation, mixing, and pouring is as follows:

**Installation** Instructions

1. Remove all laitence and foreign matter from the surface of the concrete by use of a chipping hammer. All areas coming in contact with grout should be roughened.
2. Remove all debris such as concrete chips and all moisture from the bolt sleeve by the use of an air hose.
3. The anchor bolt located within the concrete should be protected by a plastic bolt sleeve in order to prevent the grout from coming in contact with the anchor bolt. This will ensure proper stretch of the bolt.
4. If possible, fill the sleeve with a non-binding material such as ITW Expansion Joint Compound or spray foam insulation. If additional sealing is required, fill the top end of the pipe sleeve with RTV Silicone or equivalent.
5. Cover the top portion of the anchor bolt with Armaflex Pipe Insulation or wrap with foam-backed tape to prevent it from touching the grout.
6. Sand blast the bottom of the base plate to obtain a 1 to 1 ½ mil profile (SP-6) and coat with AST MS-7CZ Rust Inhibitive Primer.
7. Attach a leveling pad to the surface of the concrete foundation using Phillybond #6. This pad must be round with rounded edges and must be capable of supporting the load imposed by the leveling screw on the foundation.
8. Set and level the base plate. After leveling, apply paste wax to any areas on the base plate

that may get grout dripped on them to make it easier to clean later.

9. Apply a heavy coat of non-melt grease to all leveling screws both before and after the base plate is aligned.
10. Mix and pour the grout in accordance with "Installation Specification for Pumps and Drivers when Using Epoxy Grouts".
11. After the grout has hardened, remove the leveling screws and fill the holes with Silicone. If this is not practical back off the leveling screws a minimum of three full turns

Reference

For further design considerations and application details, please contact your local representative of our Worldwide Distributor Network or ITW Performance Polymers.

Date June 2018

General: Every reasonable effort is made to insure the technical information and recommendations on these data pages are true and accurate to the best of our knowledge at the date of issuance. However, this information is subject to change without notice. Prior versions of this publication are invalid with the release of this version. Products and information are intended for use by qualified applicators that have the required background, technical knowledge, and equipment to perform said tasks in a satisfactory manner. Consult your local distributor for product availability, additional product information, and technical support. **Warranty:** ITW Performance Polymers, a division of Illinois Tool Works Inc., warrants that its products meet their printed specifications. This is the sole warranty. This warranty expires one year after product shipment. **Warranty Claims:** If any product fails to meet the above, ITW Performance Polymers will, at its option, either replace the product or refund the purchase price. ITW Performance Polymers will have no other liability for breach of warranty, negligence, or otherwise. All warranty claims must be made in writing within one year of the date of shipment. No other claims will be considered. **Disclaimer:** ITW Performance Polymers makes no other warranty, expressed or implied, and specifically

disclaims any warranty of merchantability or fitness for a particular purpose. Suggestions concerning the use of products are not warranties. The purchaser assumes the responsibility for determining suitability of products and appropriate use. ITW Performance Polymers' sole liability, for breach of warranty, negligence or otherwise, shall be the replacement of product or refund of the purchase price, at ITW Performance Polymers' election. Under no circumstances shall ITW Performance Polymers be liable for any indirect, incidental or consequential damages. **Modification of Warranty:** No distributor or sales representative has the authority to change the above provisions. No change in the above provisions will be valid unless in writing and signed by an officer or the Technical Director of ITW Performance Polymers. No term of any purchase order shall serve to modify any provision of this document. **Mediation and Arbitration:** If any dispute arises relating to products or product warranties, either the purchaser or ITW Performance Polymers may a) initiate mediation under the then current Center for Public Resources (CPR) Model Procedure for Mediation of Business Disputes, or b) initiate a non-binding arbitration under the rules of the American Arbitration Association for the resolution of commercial disputes.